

Regler	Wert
Volume	300 k
Midrange	250 k
Tone	250 k

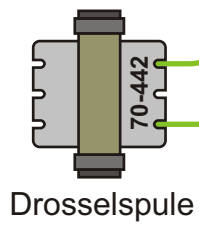

Drehschalter 3x4			
Pos.	aktive Pickups	Art	Art
1	Neck + Bridge	serial	In Phase
2	Bridge	alleine	_____
3	Neck + Bridge	parallel	In Phase
4	Neck + Bridge	serial	Out Of Phase

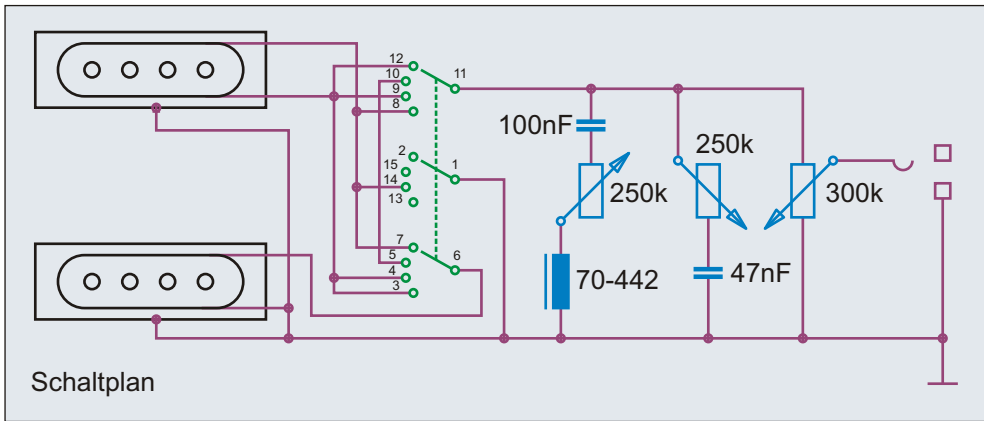

Benennung Gibson L9-S Ripper Bass 1973-83		Historische Bassschaltungen	Nummer 1.3.30
Bemerkungen / Besonderheiten Schaltung Modell 1973		gezeichnet von Cadfael	gezeichnet am 17.02.13
		Seite 100	

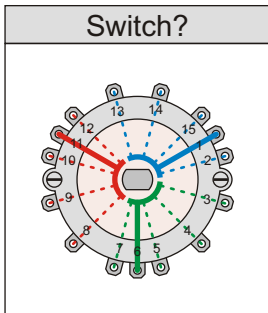
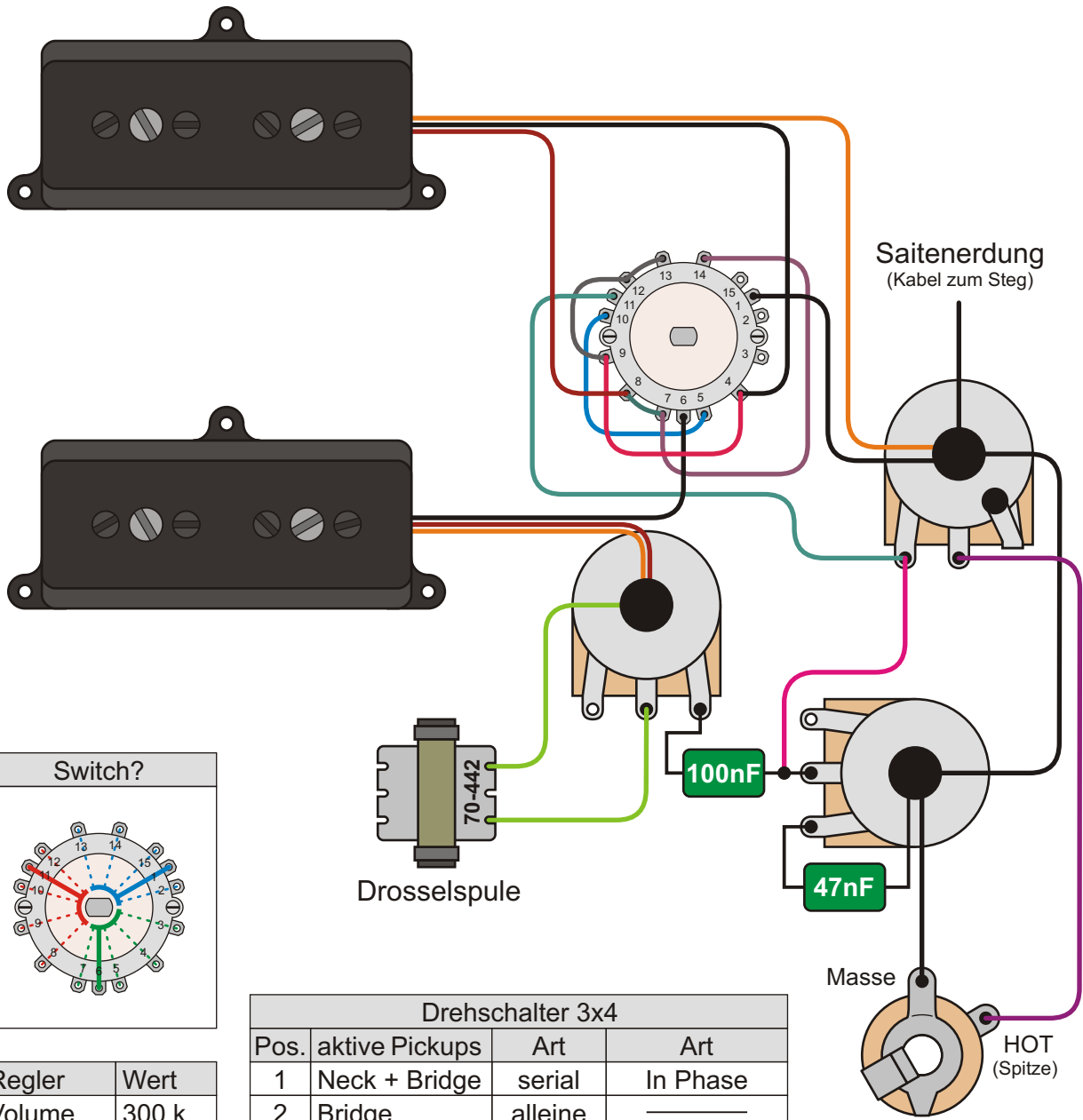

Regler	Wert
Volume	300 k
Midrange	250 k
Tone	250 k

Drehschalter 3x4			
Pos.	aktive Pickups	Art	Art
1	Neck + Bridge	serial	In Phase
2	Bridge	alleine	_____
3	Neck + Bridge	parallel	In Phase
4	Neck	alleine	_____

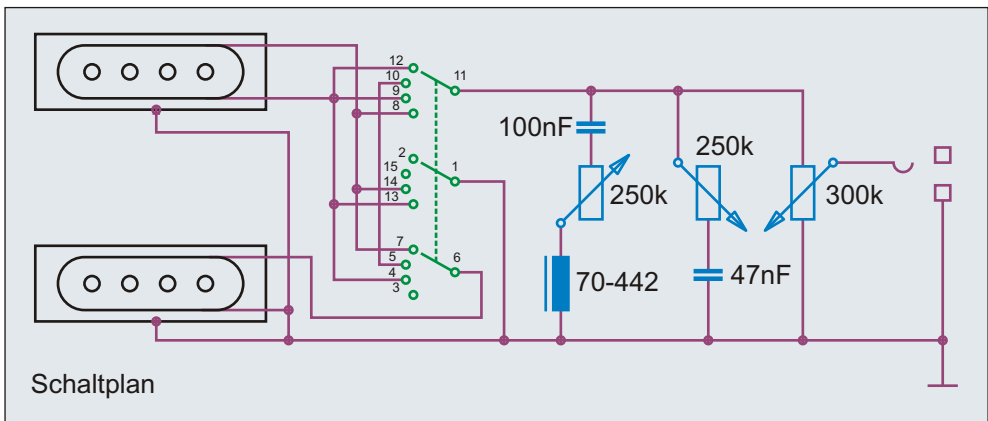

Benennung Gibson L9-S Ripper Bass 1973-83	Historische Bassschaltungen		Nummer 1.3.30
	gezeichnet von Cadfael	gezeichnet am 17.02.13	Seite 100
Bemerkungen / Besonderheiten Schaltung Modell 1973			